

TECNO
BOX

Innovamos para ti

TB1-PACK

TRAYFORMER



GENERAL FEATURES

VERSATILITY

Capable of assembling the majority of formats available on the market by changing only the accessories.

HIGH SPEED

Operation up to 2,400 cycles/hour with the possibility of increasing it to 3,000 cycles/hour with our kit.

USER FRIENDLY

Intuitive operation via touch screen for easy programming.

SECURITY

Exhaustive compliance with safety regulations and RD12/15.

OPERABILITY

New system for adjusting the hopper and suction cups without tools, reducing change times.

LOW MAINTENANCE

All consumables are standardized and easily accessible on the market.

TECHNICAL SPECIFICATIONS

MACHINE DIMENSIONS

LENGTH: 3.420 mm.

WIDTH: 2.015 mm.

HEIGHT: 2.460 mm.

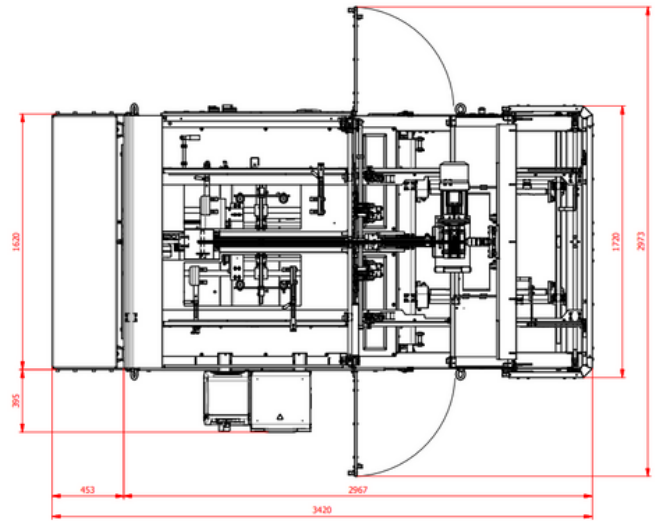

WEIGHT

1.500 Kg.

CONSUMPTION & SPECIFICATIONS

ELECTRICAL SUPPLY: 400V 3+N+PE.

TOTAL POWER: 5,5 Kw.

WORKING AIR PRESSURE: 7 BAR.

AIR CONSUMPTION AT MAXIMUM SPEED: 900 L/Min.

APPROXIMATE HOPPER CAPACITY

150 trays

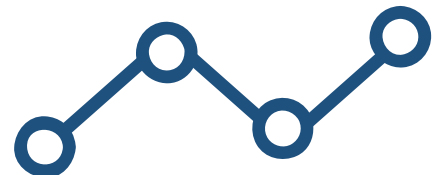

OTHER SPECIFICATIONS

□ STANDARD CONFIGURATION TB2-PACK

GLUE TANK: Meler Micron 10Kg./20 kg./Melton NC 16 Kg.

GLUE HOSES DISTRIBUTION: Direct exit/ Central distributor.

INDEPENDENT PROGRAMMING OF GLUE INJECTIONS: Included.

MANDREL'S TELESCOPE SPEED VARIATOR: Included.

AUTOMATIC ZERO POINT SEARCH: Included.

TRANSPORT WHEELS: Included.

POSITIONING SILENTBLOCKS: Included.

4 MM. CHASSIS FRAME: Included.

AUTOMATIC WATER PURGE: Included.

50L. AIR TANK: Included.

EXTERNAL AIR CONNECTION: Included.

TRAY DETECTOR IN THE HOPPER: Included.

TOUCH SCREEN: Included.

LANGUAGES: ENGLISH/SPANISH

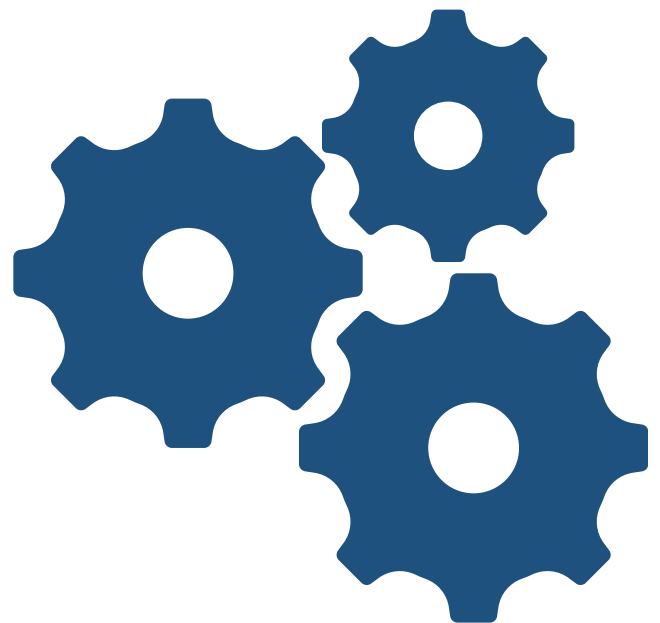

ASSEMBLING RANGE

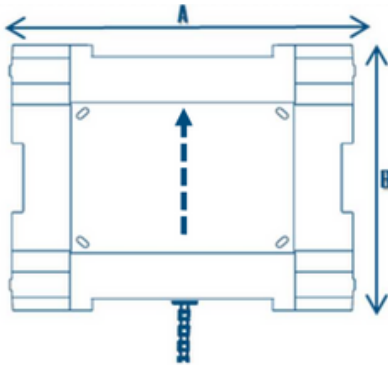

TRAY DIMENSIONS

Máx. A : 1.350mm.

Máx. B : 880 mm.

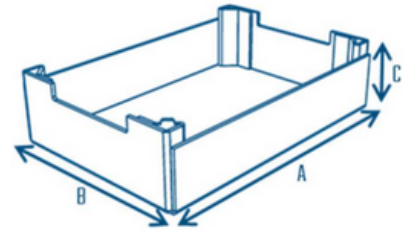

BOX DIMENSIONS

Máx. A : 800 mm. /Mín. A : 280 mm.

Máx. B : 400 mm. /Mín. B : 180 mm.

Máx. C : 280 mm. /Mín. C : 60 mm.

EXAMPLES OF BOXES



WWW.TECNOBOX.ES

TECNO
BOX
Innovamos para ti

AVAILABLE CONFIGURATIONS

SPEED INCREASE KIT

It allows the response speed of the machine to be increased from 2,400 cycles/hour to 3,000 cycles/hour.

GLUE TANK

Select between 10 and 20 kg. of capacity, as best suits your needs.



VACUUM SYSTEM

Select individual venturi system or vacuum pump.

HOSES DISTRIBUTION

Select direct exit or central distributor.



WWW.TECNOBOX.ES

**TECNO
BOX**
Innovamos para ti

NOVELTIES OF THE TB-PACK RANGE

TOOL-FREE ADJUSTABLE HOPPER

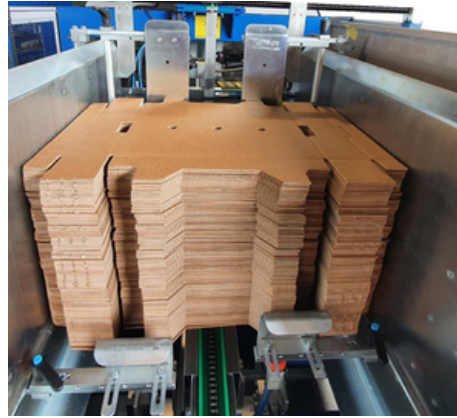

ADJUSTMENT OF SUCTION CUPS WITH COUNTER



LARGER SIZE ELECTRICAL CABINET

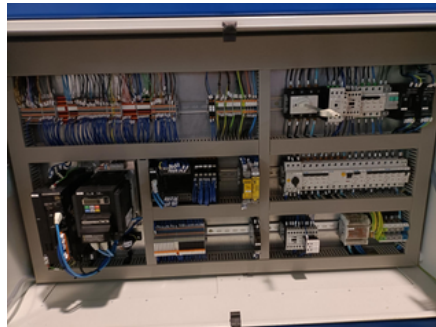

EXIT SYSTEM FOR TB-PACK

STACKER AP-PACK



Designed for stacking set-type formats. It allows you to control the number of boxes per stack, as well as the speed of the belt from its touch screen. Capable of stacking up to 3 stacks simultaneously.



STACKER AND COLLAPSER APC-PACK



Box folding stacker, to facilitate stock storage. Possibility of installing a strapping system to generate packages.



TRANSPORT BELT ACC-PACK

Flat or inclined transport belt made to measure according to the customer's needs. Intended for connection to packaging lines or for non-stackable formats.

